

Instructions – Parts List



19 LITER (5 GALLON)

Wiper Plates

308049S

***For straight-sided or tapered pails.
Fit Check-Mate™ Pumps on a Pneumatic Elevator Cart or Ram.***

U.S. Patent No. 5,117,998



Important Safety Instructions

Read all warnings and instructions in this manual.
Save these instructions.

See page 2 for Table of Contents and List of
Models.

Model 222812

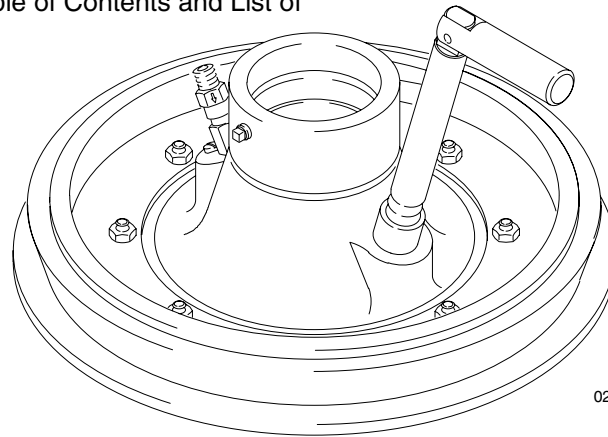

0212A

Model 222909

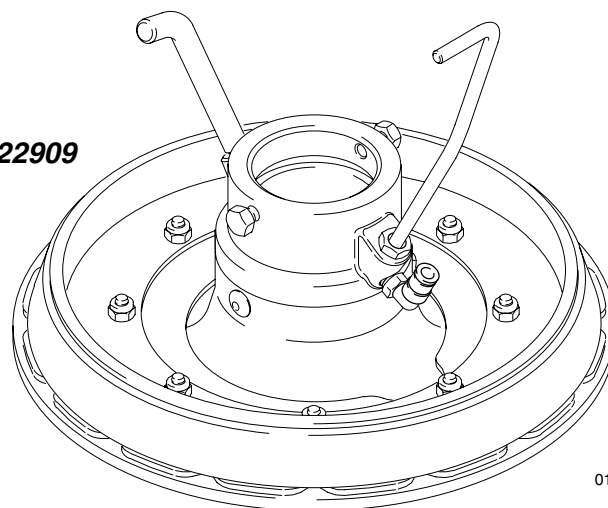

01115

Table of Contents

List of Models	2	Installation on a Ram (Stainless Steel Plates)	10
Symbols	3	Installation on a Cart (Stainless Steel Plates)	12
Warnings	3	Parts Drawings and Lists	14
Installation (All Wiper Plates)	5	Accessories	21
Installation on a Ram		Technical Data	21
(Carbon Steel or Aluminum Plates)	6	Graco Standard Warranty	22
Installation on a Cart		Graco Information	22
(Carbon Steel or Aluminum Plates)	8		

List of Models

Model No.	Series	Plate Material	Wiper Material	Backup Material	Installation Pages	Parts Pages
222812	B	Carbon Steel	Buna-N	UHMWPE	6-9	14
235516	B	Carbon Steel	PTFE-coated	UHMWPE	6-9	15
222909	A	Stainless Steel	PTFE-coated	UHMWPE	10-13	16-17
241081	A	Carbon Steel	Buna-N	UHMWPE	6-9	18
918409	B	Carbon Steel	Buna-N	UHMWPE	6-9	19
C50010	B	Carbon Steel	Buna-N	UHMWPE	6-9	20
C50260	B	Carbon Steel	Buna-N	UHMWPE	6-9	14

Symbols

Warning Symbol



This symbol alerts you to the possibility of serious injury or death if you do not follow the instructions.

Caution Symbol



This symbol alerts you to the possibility of damage to or destruction of equipment if you do not follow the instructions.

! WARNING



INSTRUCTIONS

EQUIPMENT MISUSE HAZARD

Equipment misuse can cause the equipment to rupture or malfunction and result in serious injury.

- This equipment is for professional use only.
- Read all instruction manuals, tags, and labels before operating the equipment.
- Use the equipment only for its intended purpose. If you are uncertain about usage, call your Graco distributor.
- Do not alter or modify this equipment. Use only genuine Graco parts and accessories.
- Check equipment daily. Repair or replace worn or damaged parts immediately.
- Use fluids and solvents which are compatible with the equipment wetted parts. Refer to the **Technical Data** section of all equipment manuals. Read the fluid and solvent manufacturer's warnings.
- Comply with all applicable local, state, and national fire, electrical, and safety regulations.



MOVING PARTS HAZARD

Moving parts, such as the priming piston and wiper plate, can pinch or amputate your fingers.

- Keep clear of all moving parts when starting or operating the pump.
- Keep hands and fingers away from the priming piston during operation and whenever the pump is charged with air.
- Keep your hands away from the wiper plate and the lip of the pail while the ram is operating.
- Before servicing the equipment, follow the **Pressure Relief Procedure** on page 5 to prevent the equipment from starting unexpectedly.

Installation (All Wiper Plates)

Pressure Relief Procedure

WARNING



SKIN INJECTION HAZARD

The system pressure must be manually relieved to prevent the system from starting or spraying accidentally. Fluid under high pressure can be injected through the skin and cause serious injury. To reduce the risk of an injury from injection, splashing fluid, or moving parts, follow the **Pressure Relief Procedure** whenever you:

- are instructed to relieve the pressure,
- stop spraying/dispensing,
- check or service any of the system equipment,
- or install or clean the spray tip/nozzle.

1. Lock the gun/valve trigger safety.
2. Close the pump air bleed valve (required in your system).
3. Shut off the main air bleed valve (required in your system).
4. Unlock the gun/valve trigger safety.
5. Hold a metal part of the gun/valve firmly to the side of a grounded metal pail, and trigger the gun/valve to relieve pressure.
6. Lock the gun/valve trigger safety.
7. Open the drain valve (required in your system) and/or the pump bleeder valve, having a container ready to catch the drainage.
8. Leave the drain valve open until you are ready to spray again.

If you suspect that the spray tip/nozzle or hose is completely clogged, or that pressure has not been fully relieved after following the steps above, very slowly loosen the tip guard retaining nut or hose end coupling and relieve pressure gradually, then loosen completely. Now clear the tip/nozzle or hose.

Installation on a Ram

(Carbon Steel or Aluminum Plates)

Installation

Reference letters and numbers in the text refer to Figs. 1–4 and the Parts Drawings on pages 14–15.

WARNING

MOVING PARTS HAZARD



Moving parts can pinch or amputate your fingers. When the pump is operating and when raising or lowering the ram, keep your fingers and hands away from the priming piston and the lip of the pail.

WARNING

To reduce the risk of serious injury, whenever you are instructed to relieve pressure, always follow the **Pressure Relief Procedure** on page 5.

1. Relieve the pressure.
2. Install the wiper plate (A) onto the pump intake (B), with the wiper plate vent handle (C) facing the front of the ram. Secure by tightening the setscrew (3). See Fig. 1.
3. The wiper plate is supplied for use with 19 liter (5 gallon) straight sided pails, but it can be easily modified for use with tapered pails. See steps a and b.
 - a. **To use the wiper plate with tapered pails**, the large spacer (19) must be removed. *Working from the bottom*, use a screwdriver to pry the spacer loose. Work it upward so it is completely above the flange (D) of the wiper plate. See Fig. 2. Next, by hand, angle the spacer and work it off the plate, pulling it down over the flange and bottom wipers (E). See Fig. 3. Save the spacer, as it is required for other applications.

- b. **To reinstall the spacer for use with a straight sided pail**, first make sure the large diameter of the spacer (19) is facing **down**. Work the spacer up over the wiper plate by hand, so it is completely above the flange (D) of the wiper plate. See Fig. 3. Then, *working from the top*, use a screwdriver to position the spacer between the flange (D) and the wipers (E). See Fig. 4.

4. Connect a 610 mm (24 in.), 1/4 in. (6.3 mm) OD nylon tube (F) with a 1/8 npt(f) fitting (H) from the ram's air assist tube fitting (G) to the air assist check valve (21) on the wiper plate.
5. Refer to the separate ram and pump manuals for set-up and operating instructions.

Maintenance

If the wiper plate does not come out of the pail easily when the pump is being raised, the air assist tube (F), fitting (H), and check valve (21) may be plugged. This prevents air from reaching the underside of the plate to assist in raising it from the pail.

WARNING

To reduce the risk of serious injury whenever you are instructed to relieve pressure, always follow the **Pressure Relief Procedure** on page 5.

Relieve the pressure. Refer to the Parts Drawings on pages 14–15 and disassemble the air assist check valve as shown. Clear the tube (F) and the port in the wiper plate. Clean all parts of the check valve assembly, and reassemble.

Installation on a Ram

(Carbon Steel and Aluminum Plates)

**Installing the Wiper Plate on a Ram
(Model 222812 shown; large diameter of
spacer facing down)**

1 To use Model 222812 and 235516, Plates with tapered pails, the spacer (19) must be removed. See page 6, and Figs. 2-4.

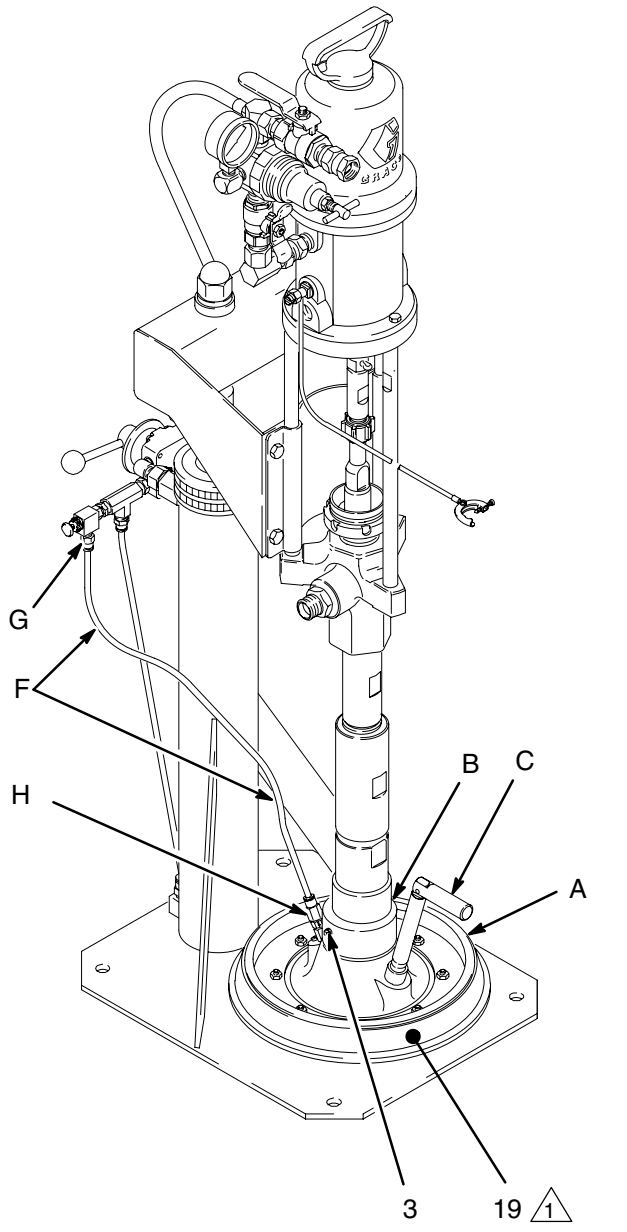

Fig. 1

06540A

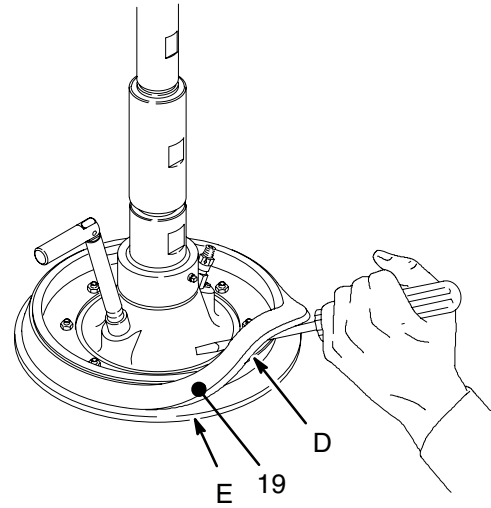

Fig. 2

0248A

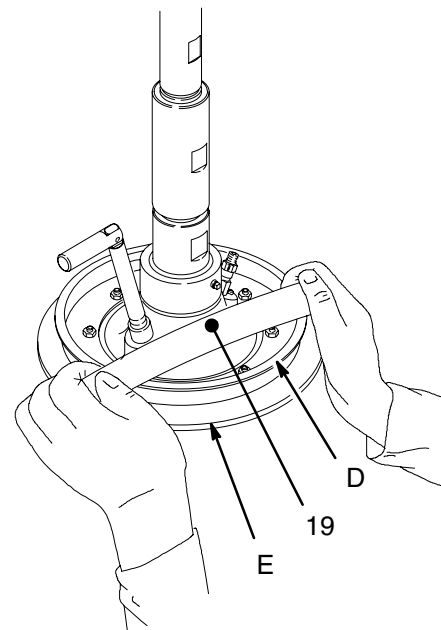

Fig. 3

0249A

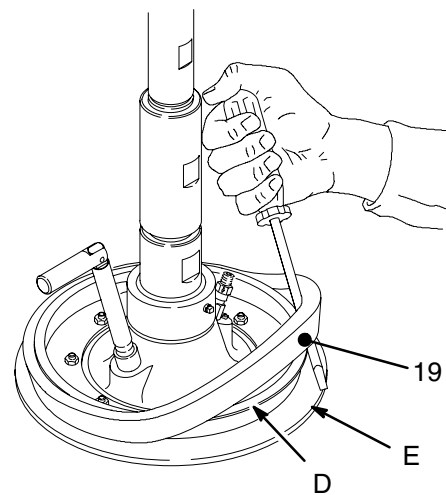

Fig. 4

0251A

Installation on a Cart

(Carbon Steel and Aluminum Plates)

Installation

Reference letters and numbers in the text refer to Figs. 5–8 and the Parts Drawings on pages 14–15.

WARNING

MOVING PARTS HAZARD



Moving parts can pinch or amputate your fingers. When the pump is operating and when raising or lowering the ram, keep your fingers and hands away from the priming piston and the lip of the pail.

WARNING

To reduce the risk of serious injury whenever you are instructed to relieve pressure, always follow the **Pressure Relief Procedure** on page 5.

1. Relieve the pressure.
2. Install the wiper plate (A) onto the pump intake (B), with the wiper plate vent handle (C) facing the front of the cart. Secure by tightening the setscrew (3). See Fig. 5.
3. The wiper plate is supplied for use with 19 liter (5 gallon) straight sided pails on a ram. It must be modified for use with the pneumatic elevator cart. See steps a and b, following.
 - a. **To use the wiper plate with straight sided pails**, the large spacer (19) must be inverted. *Working from the bottom*, use a screwdriver to pry the spacer loose. Work it upward so it is completely above the flange (D) of the wiper plate. See Fig. 6. Next, by hand, angle the spacer and work it off the plate, pulling it down over the flange and bottom wipers (E). See Fig. 7. Turn the spacer so the large diameter is facing **up**. Work the spacer up over the wiper plate by hand, so it is completely above the flange (D) of the wiper plate. *Working from the top*, use a screwdriver to position the spacer between the flange (D) and the wipers (E). See Fig. 8.

- b. **To use the wiper plate with tapered pails**, the large spacer (19) must be removed. *Working from the bottom*, use a screwdriver to pry the spacer loose. Work it upward so it is completely above the flange (D) of the wiper plate. See Fig. 6. Next, by hand, angle the spacer and work it off the plate, pulling it down over the flange and bottom wipers (E). See Fig. 7. Save the spacer, as it is required for other applications.

4. Install Cart Accessory Kit 224376. See 308087 for details.
5. Refer to the separate cart and pump manuals for set-up and operating instructions.

Maintenance

If the wiper plate does not come out of the pail easily when the pump is being raised, the air assist tube (F), fitting (H), or check valve (21) may be plugged. This prevents air from reaching the underside of the plate to assist in raising it from the pail.

WARNING

To reduce the risk of serious injury whenever you are instructed to relieve pressure, always follow the **Pressure Relief Procedure** on page 5.

Relieve the pressure. Refer to the Parts Drawings on pages 14–15 and disassemble the air assist check valve as shown. Clear the tube (F) and the port in the wiper plate. Clean all parts of the check valve assembly, and reassemble.

Installation on a Cart

(Carbon Steel and Aluminum Plates)

Installing the Wiper Plate on a
Pneumatic Elevator Cart
(Model 222812 shown;
large diameter of spacer facing up)

1 To use Model 222812 and 235516 Plates with tapered pails, the spacer (19) must be removed. See page 8, and Figs. 6-8.

2 Part of Kit 224376 (See 308087).

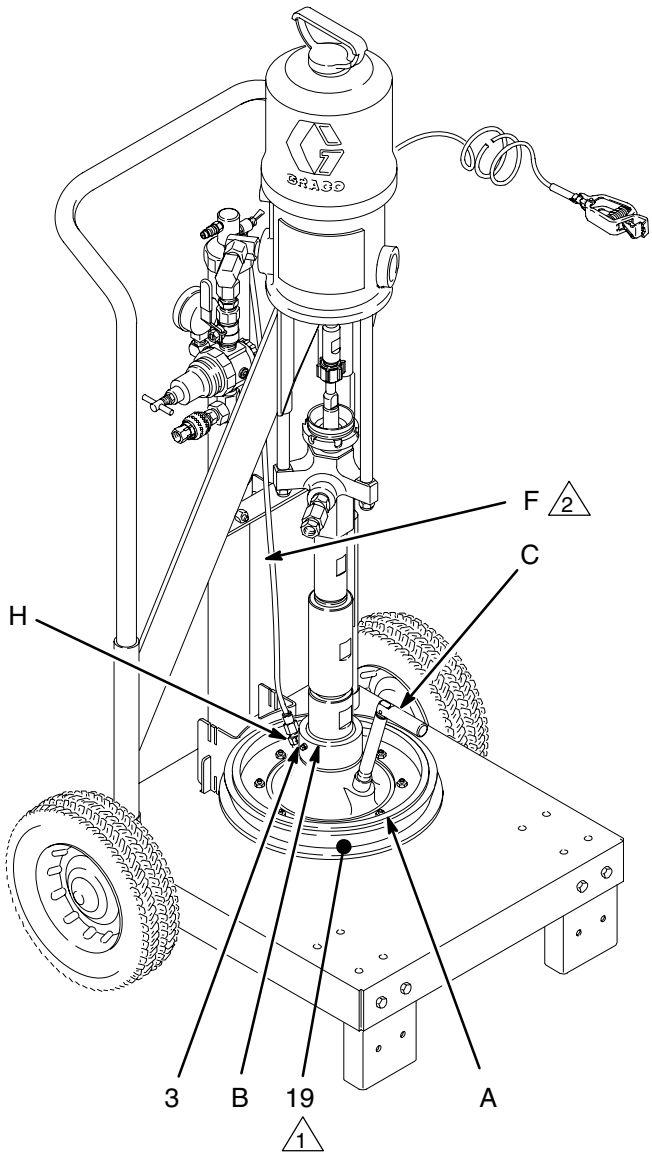

0252D

Fig. 5

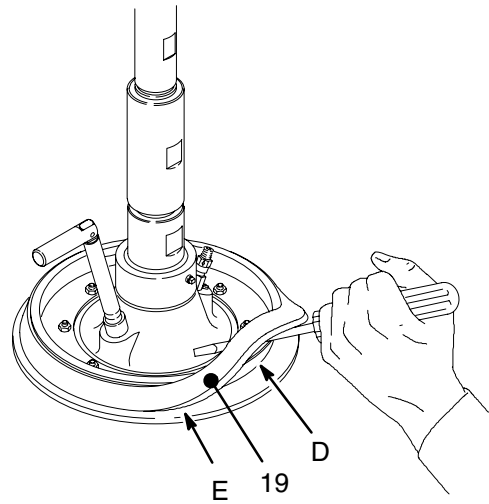

0248A

Fig. 6

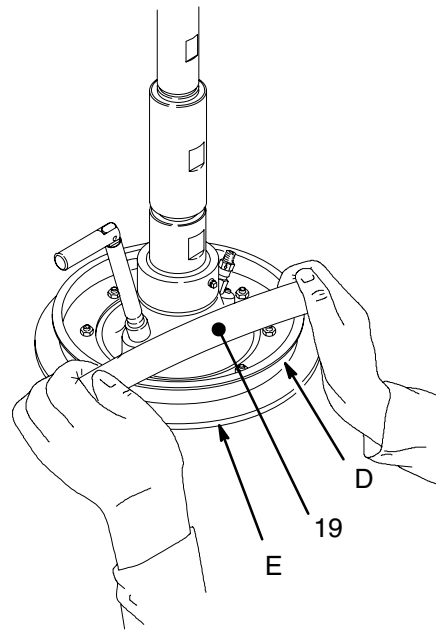

0249A

Fig. 7

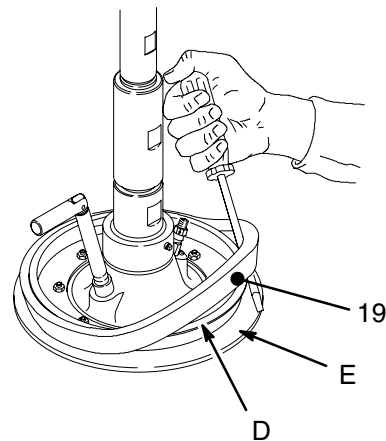

0251A

Fig. 8

Installation on a Ram

(Stainless Steel Plates)

Installation

Reference letters and numbers in the text refer to Figs. 9–12 and the Parts Drawing on page 16.

WARNING



MOVING PARTS HAZARD

Moving parts can pinch or amputate your fingers. When the pump is operating and when raising or lowering the ram, keep your fingers and hands away from the priming piston and lip of the pail.

WARNING

To reduce the risk of serious injury whenever you are instructed to relieve pressure, always follow the **Pressure Relief Procedure** on page 5.

1. Relieve the pressure.
2. Install the wiper plate (A) onto the pump intake (B), with the wiper plate vent handle (C) facing the left of the ram. Secure by tightening the setscrews (17). See Fig. 9.
3. The wiper plate is supplied for use with 19 liter (5 gallon) straight sided pails, but it can be easily modified for use with tapered pails. See steps a and b
 - a. **To use the wiper plate with tapered pails**, the large spacer (8) must be removed. *Working from the bottom*, use a screwdriver to pry the spacer loose. Work it upward so it is completely above the flange (D) of the wiper plate. See Fig. 10. Next, by hand, angle the spacer and work it off the plate, pulling it down over the flange and bottom wipers (E). See Fig. 11. Save the spacer, as it is required for other applications.
 - b. **To reinstall the spacer for use with a straight sided pail**, first make sure the large diameter of the spacer (8) is facing **down**. Work the spacer up over the wiper plate by hand, so it is completely above the flange (D) of the wiper plate. See Fig. 11. Then, *working from the top*, use a screwdriver to position the spacer between the flange (D) and the wipers (E). See Fig. 12.

4. Connect a 965 mm (38 in.), 6.3 mm (1/4 in.) OD tube (F) from the ram's air assist valve (G) to the elbow (H) on the wiper plate.
5. Refer to the separate ram and pump manuals for set-up and operating instructions.

Operating the Air Assist Valve Handle

The ram's air assist valve (G) directs air under the wiper plate, making it easier to pull the plate out of the pail. For the air assist valve to function, you must open a passage for the air with the valve handle (J). Practice using the handle a few times, until you are familiar with its use.

WARNING

To reduce the risk of serious injury whenever you are instructed to relieve pressure, always follow the **Pressure Relief Procedure** on page 5.

1. Stop the pump. Relieve the pressure.
2. To open a passage for air to get under the plate, rotate the handle (J) 45° **clockwise** and pull it upward (it should travel about 13 mm [1/2 in.] up and down).
3. Turn the ram director valve to UP. Press the air assist valve (G), and hold it in until the plate clears the top of the pail.
4. To close the air passage, push the handle (J) down and rotate it 45° **counterclockwise** to lock.

Maintenance

If the wiper plate does not come out of the pail easily when the pump is being raised, the air assist tube (F), elbow (H), or valve (J) may be plugged. A plugged valve prevents air from reaching the underside of the plate to assist in raising it from the pail.

WARNING

To reduce the risk of serious injury whenever you are instructed to relieve pressure, always follow the **Pressure Relief Procedure** on page 5.

Relieve the pressure. Refer to the Parts Drawing on page 16 and disassemble the air assist valve (J) as shown. Clear the hose (F) and the elbow (H) in the wiper plate. Clean all parts of the valve, and reassemble.

Installation on a Ram

(Stainless Steel Plates)

Installing the Wiper Plate on a Ram (large diameter of spacer facing down)

 To use Model 222909 Plate with a tapered pail, the spacer (8) must be removed. See page 10, and Figs. 10–12.

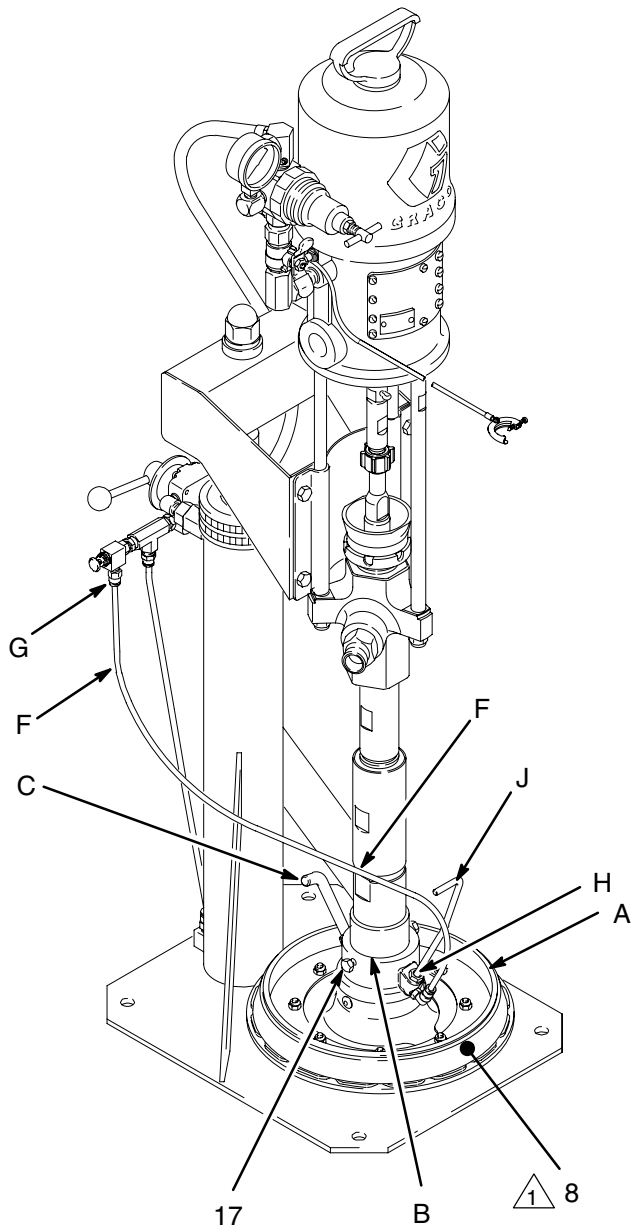

Fig. 9

06754C

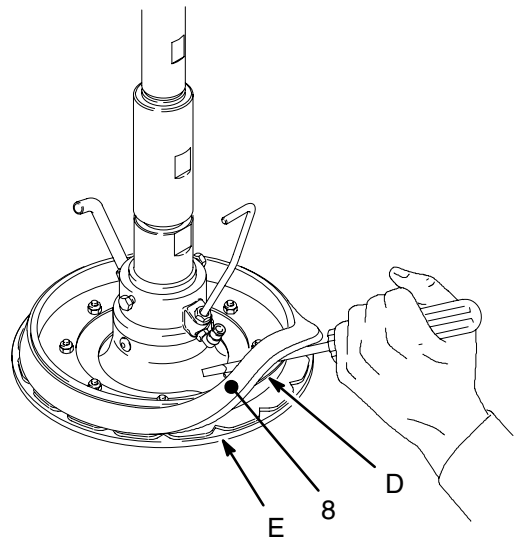

Fig. 10

01116

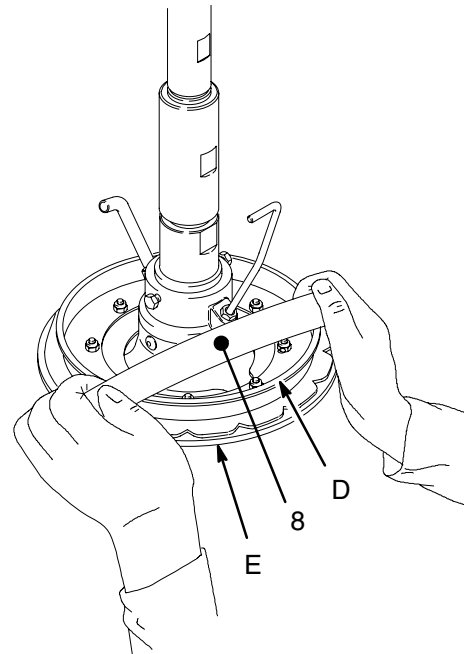

Fig. 11

01117

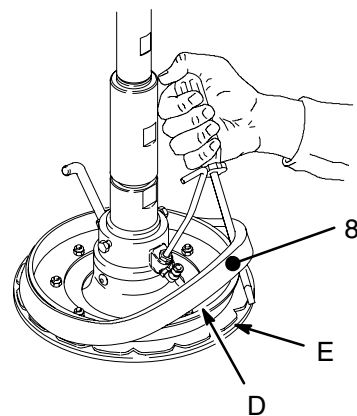

Fig. 12

01118

Installation on a Cart

(Stainless Steel Plates)

Installation

Reference letters and numbers in the text refer to Figs. 13–16 and the Parts Drawing on page 16.

WARNING

MOVING PARTS HAZARD



Moving parts can pinch or amputate your fingers. When the pump is operating and when raising or lowering the ram, keep your fingers and hands away from the priming piston and the lip of the fluid container.

WARNING

To reduce the risk of serious injury whenever you are instructed to relieve pressure, always follow the **Pressure Relief Procedure** on page 5.

1. Relieve the pressure.
2. Install the wiper plate (A) onto the pump intake (B), with the wiper plate vent handle (C) facing the left of the cart. Secure by tightening the setscrews (17). See Fig. 13.
3. The wiper plate is supplied for use with 19 liter (5 gallon) straight sided pails on a ram. It must be modified for use with the pneumatic elevator cart. See steps a and b following.
 - a. **To use the wiper plate with straight sided pails**, the large spacer (8) must be inverted. *Working from the bottom*, use a screwdriver to pry the spacer loose. Work it upward so it is completely above the flange (D) of the wiper plate. See Fig. 14. Next, by hand, angle the spacer and work it off the plate, pulling it down over the flange and bottom wipers (E). See Fig. 15. Turn the spacer so the large diameter is facing **up**. Work the spacer up over the wiper plate by hand, so it is completely above the flange (D) of the wiper plate. *Working from the top*, use a screwdriver to position the spacer between the flange (D) and the wipers (E). See Fig. 16.
 - b. **To use the wiper plate with tapered pails**, the large spacer (8) must be removed. *Working from the bottom*, use a screwdriver to pry the spacer loose. Work it upward so it is completely above the flange (D) of the wiper plate. See Fig. 14. Next, by hand, angle the spacer and work it off the plate, pulling it down over the flange and bottom wipers (E). See Fig. 15. Save the spacer, as it is required for other applications.

4. Install Cart Accessory Kit 224376. See 308199 for details.
5. Refer to the separate cart and pump manuals for set-up and operating instructions.

Operating the Air Assist Valve Handle

The cart's air assist toggle valve (G) directs air under the wiper plate, making it easier to pull the plate out of the pail. Refer to manual 308199 for instructions on changing pails using the air assist valve.

For the air assist valve to function, you must open a passage for the air with the valve handle (J). Practice using the handle a few times, until you are familiar with its use.

WARNING

To reduce the risk of serious injury whenever you are instructed to relieve pressure, always follow the **Pressure Relief Procedure** on page 5.

1. Relieve the pressure.
2. To open a passage for air to get under the plate, rotate the handle (J) 45° **clockwise** and pull it upward (it should travel about 13 mm [1/2 in.] up and down).
3. To close the air passage, push the handle (J) down and rotate it 45° **counterclockwise** to lock.

Maintenance

If the wiper plate does not come out of the pail easily when the pump is being raised, the air assist tube (F), elbow (H), or valve (J) may be plugged. A plugged valve prevents air from reaching the underside of the plate to assist in raising it from the pail.

WARNING

To reduce the risk of serious injury whenever you are instructed to relieve pressure, always follow the **Pressure Relief Procedure** on page 5.

Relieve the pressure. Refer to the Parts Drawing on page 16 and disassemble the air assist valve (J) as shown. Clear the hose (F) and the elbow (H) in the wiper plate. Clean all parts of the valve, and reassemble.

Installation on a Cart

(Stainless Steel Plates)

Installing the Wiper Plate on a Pneumatic Elevator Cart (large diameter of spacer facing up)

1 To use Model 222909 Plate with a tapered pail, the spacer (8) must be removed. See page 12, and Figs. 14–16.

2 Part of Kit 224376; see 308199.

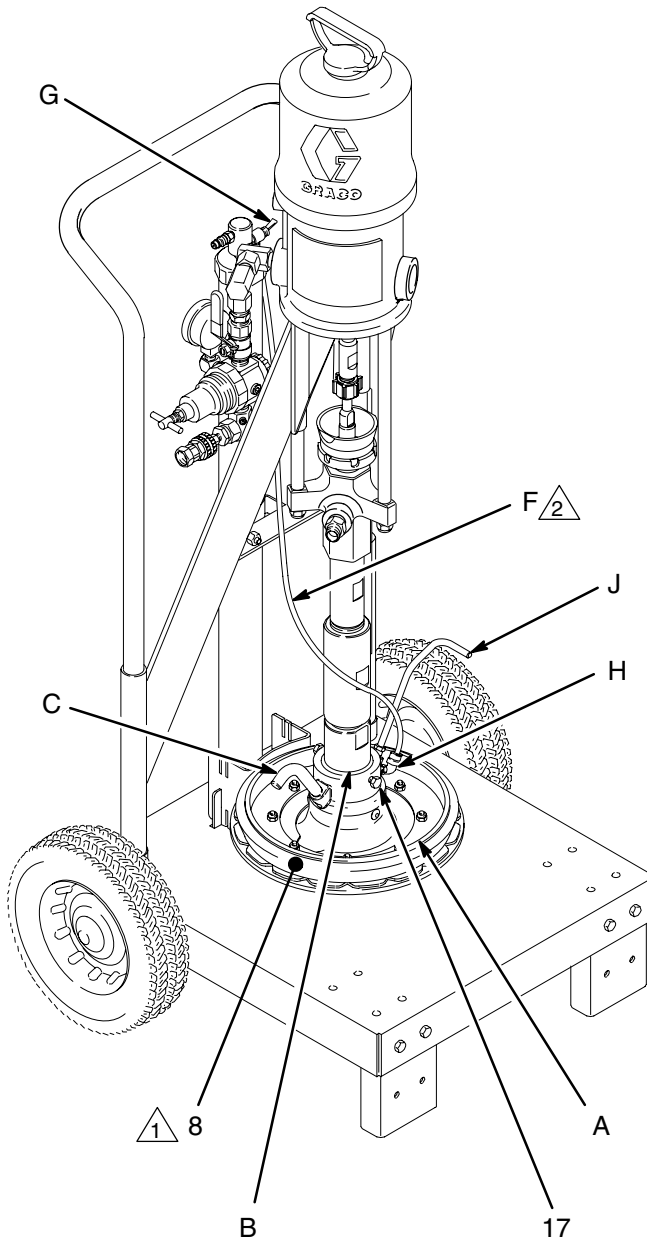

Fig. 13

01096

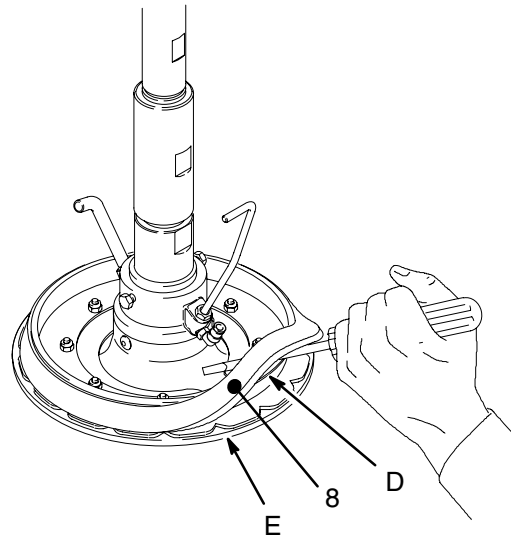

Fig. 14

01116

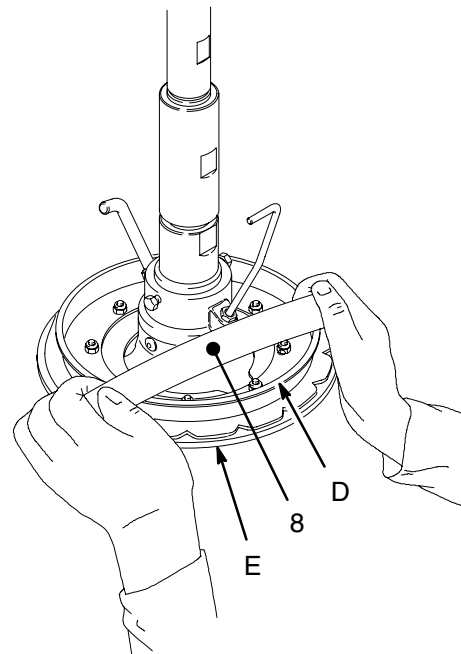

Fig. 15

01117

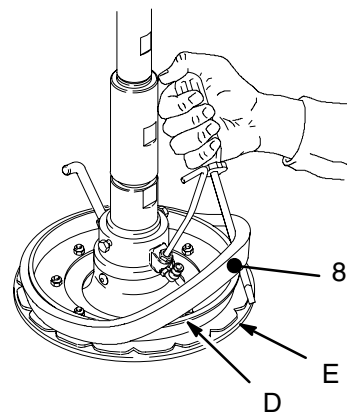
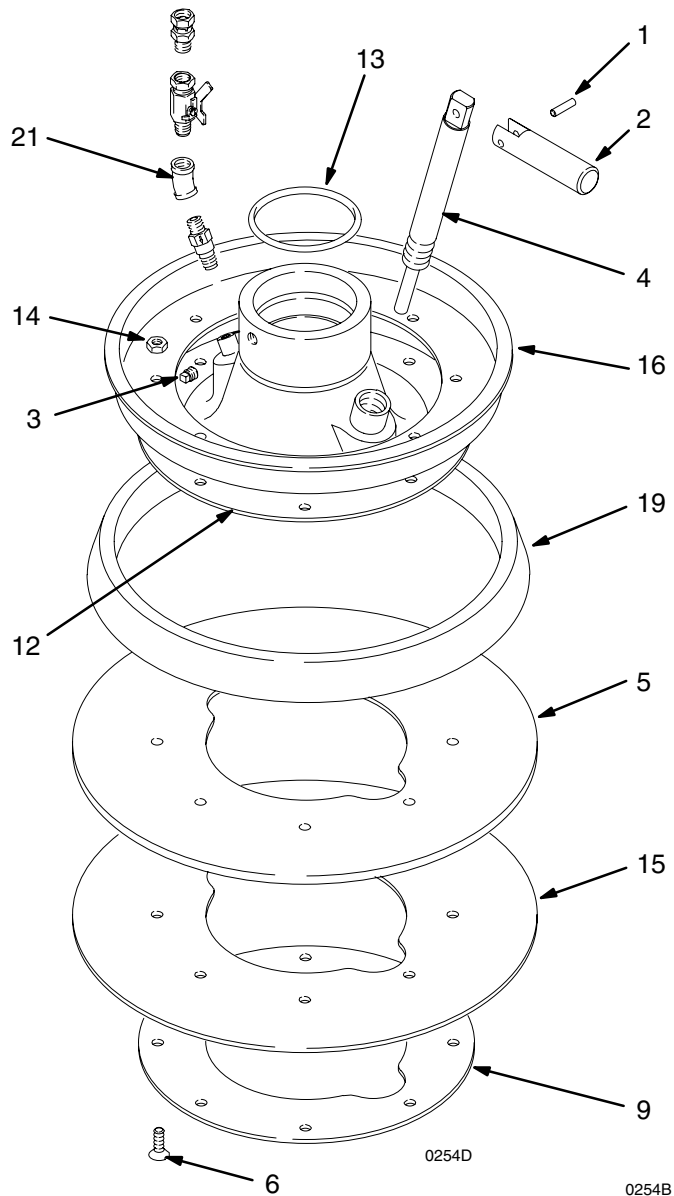

Fig. 16

01118

Parts

Model C50260, Series B
Model 222812, Series B
Carbon Steel Wiper Plate
with Buna-N Wiper
and UHMWPE Backup



Ref. No.	Part No.	Description	Qty	Ref. No.	Part No.	Description	Qty
1	101831	PIN, spring, straight	1	13	109458	O-RING; fluoroelastomer	1
2	177542	HANDLE	1	14	102040	NUT, hex, self-locking; with nylon insert; 1/4-20 unc-3b	8
3	109468	SETSCREW, hex hd, cup point; 5/16-18 x 3/8 in. (9.5 mm) long	2	15 ✓	184421	WIPER; polyethylene (Model 222812 only)	1
4	166560	STEM, probe	1	16	184418	CLAMP, retaining; zinc-plated carbon steel	1
5 ✓	184420	WIPER; synthetic rubber	1	19	276049	SPACER; polyurethane	1
6	109469	SCREW, machine, flat-hd; zinc-plated carbon steel; 1/4-20 x 1 in. (25 mm) long	8	21	114317	VALVE, check, air assist	1
9	184419	CLAMP, retaining; zinc-plated carbon steel	1	✓ Keep these spare parts on hand to reduce down time.			
12	222764	PLATE, wiper; zinc-plated carbon steel	1				

Parts

Model 235516, Series B Carbon Steel Wiper Plate with PTFE-coated Wiper and UHMWPE Backup

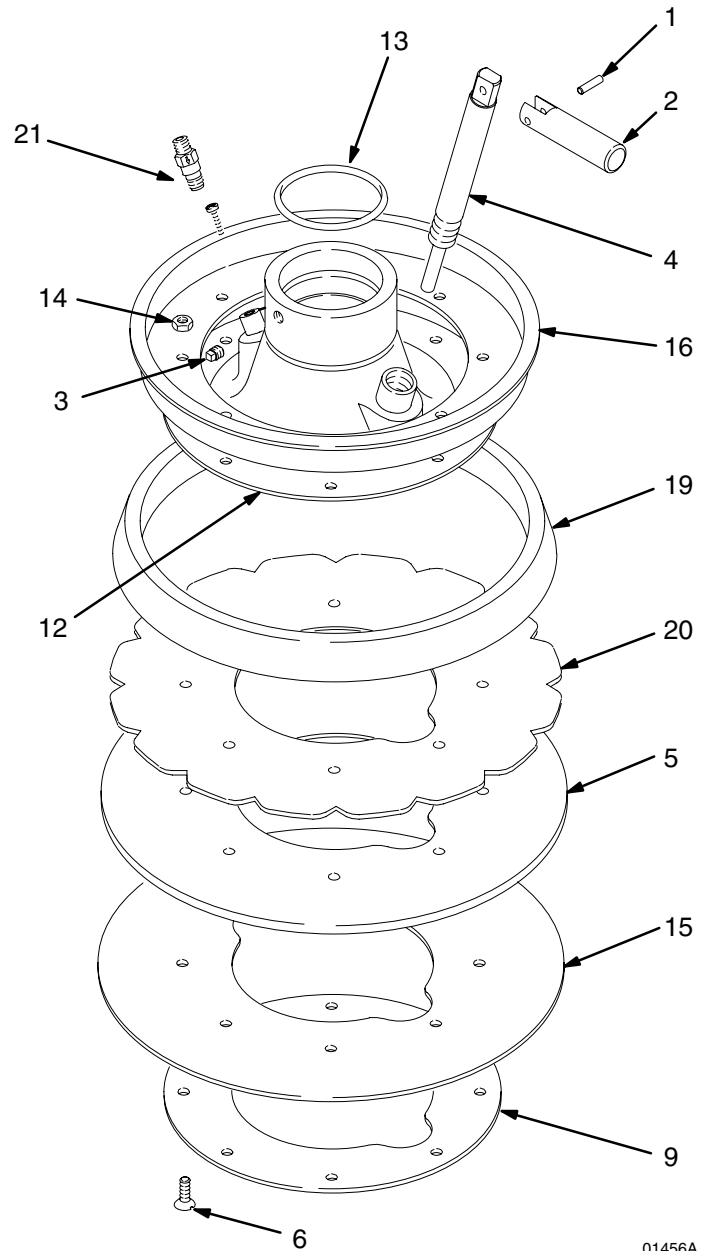

01456A

Ref. No.	Part No.	Description	Qty	Ref. No.	Part No.	Description	Qty
1	101831	PIN, spring, straight	1	13	109458	O-RING; fluoroelastomer	1
2	177542	HANDLE	1	14	102040	NUT, hex, self-locking; with nylon insert; 1/4-20 unc-3b	8
3	109468	SETSCREW, hex hd, cup point; 5/16-18 x 3/8 in. (9.5 mm) long	1	15	184421	WIPER; polyethylene	1
4	166560	STEM, probe	1	16	184418	CLAMP, retaining; zinc-plated carbon steel	1
5	184552	WIPER; nitrile/PTFE	1	19	276049	SPACER; polyurethane	1
6	109469	SCREW, machine, flat-hd; zinc-plated carbon steel; 1/4-20 x 1 in. (25 mm) long	8	20	184551	WIPER; polyethylene	1
9	184419	CLAMP, retaining; zinc-plated carbon steel	1	21	114317	VALVE, check, air assist	1
12	222764	PLATE, wiper; zinc-plated carbon steel	1				

✓ Keep these spare parts on hand to reduce down time.

Parts

Model 222909, Series A Stainless Steel Wiper Plate with PTFE-coated Wiper and UHMWPE Backup

Ref. No.	Part No.	Description	Qty	Ref. No.	Part No.	Description	Qty
1	184471	COLLAR, wiper plate; sst	1	12	109479	PIN, spring, straight; 3/32 in. size x 3/8 in. (9.5 mm) long	1
2	184481	STEM, probe; sst	1	13	184482	NUT, retainer; sst	1
3	109482	O-RING; PTFE	1	14	184479	STEM, valve; sst	1
4	103972	SCREW, drive, u-type; 0.188 in. (5 mm) long	3	15✓	194147	GUIDE, valve; sst	1
5	222915	PLATE, wiper; sst	1	16	109458	O-RING; fluoroelastomer	1
6✓	184421	WIPER; polyethylene	1	17	109477	SCREW, cap, hex head; 5/16–18 unc–2a; 1/2 in. (13 mm) long	2
7✓	184552	WIPER; nitrile/PTFE	1	19✓	184530	SEAL, valve; PTFE	2
8	276049	SPACER; polyurethane	1	20✓	184551	WIPER; polyethylene	1
9	184477	CLAMP, retaining; sst	1	21	114317	VALVE, check, air assist	1
10	109478	NUT, lock, hex; w/nylon insert; 1/4–20 unc–2b	8				
11	109506	ELBOW, tube fitting, 90°; 1/8 npt(m) x 1/4 in. (6.3 mm) tube size	1				

✓ Keep these spare parts on hand to reduce down time.

**Model 241081, Series A
Carbon Steel Wiper Plate
with Buna-N Wiper
and UHMWPE Backup**

Parts

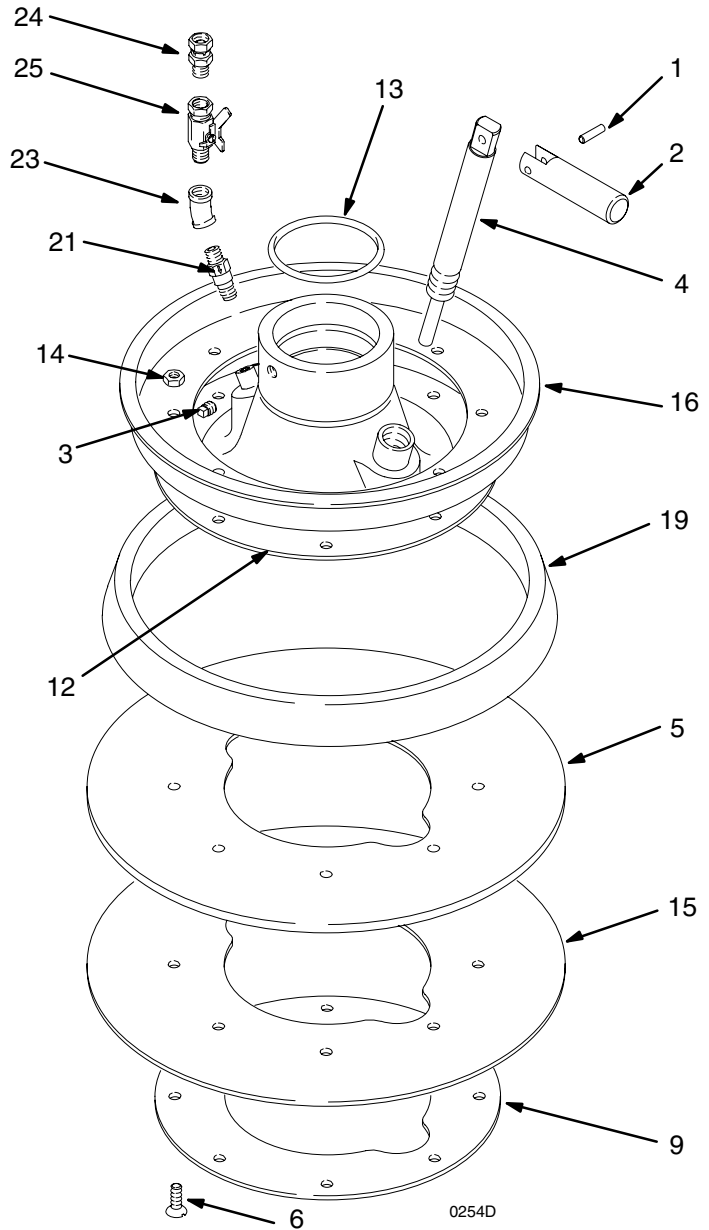

Ref. No.	Part No.	Description	Qty	Ref. No.	Part No.	Description	Qty
1	101831	PIN, spring, straight	1	13	109458	O-RING; fluoroelastomer	1
2	177542	HANDLE	1	14	102040	NUT, hex, self-locking; with nylon insert; 1/4-20 unc-3b	8
3	109468	SETSCREW, hex hd, cup point; 5/16-18 x 3/8 in. (9.5 mm) long	2	15	194147	WIPER; polyethylene	1
4	166560	STEM, probe	1	16	194149	CLAMP, retaining; zinc-plated carbon steel	1
5	194146	WIPER; synthetic rubber	1	19	276049	SPACER; polyurethane	1
6	109469	SCREW, machine, flat-hd; zinc-plated carbon steel; 1/4-20 x 1 in. (25 mm) long	8	21	C20467	VALVE, check, air assist	1
9	194151	CLAMP, retaining; zinc-plated carbon steel	1	23	111842	FITTING, elbow, pipe 45°	1
12	241080	PLATE, wiper; zinc-plated carbon steel	1	24	155665	UNION, adapter	1
				25	208391	VALVE, ball	1

✓ Keep these spare parts on hand to reduce down time.

Parts

Model 918409, Series B Carbon Steel Wiper Plate with Buna-N Wiper and UHMWPE Backup

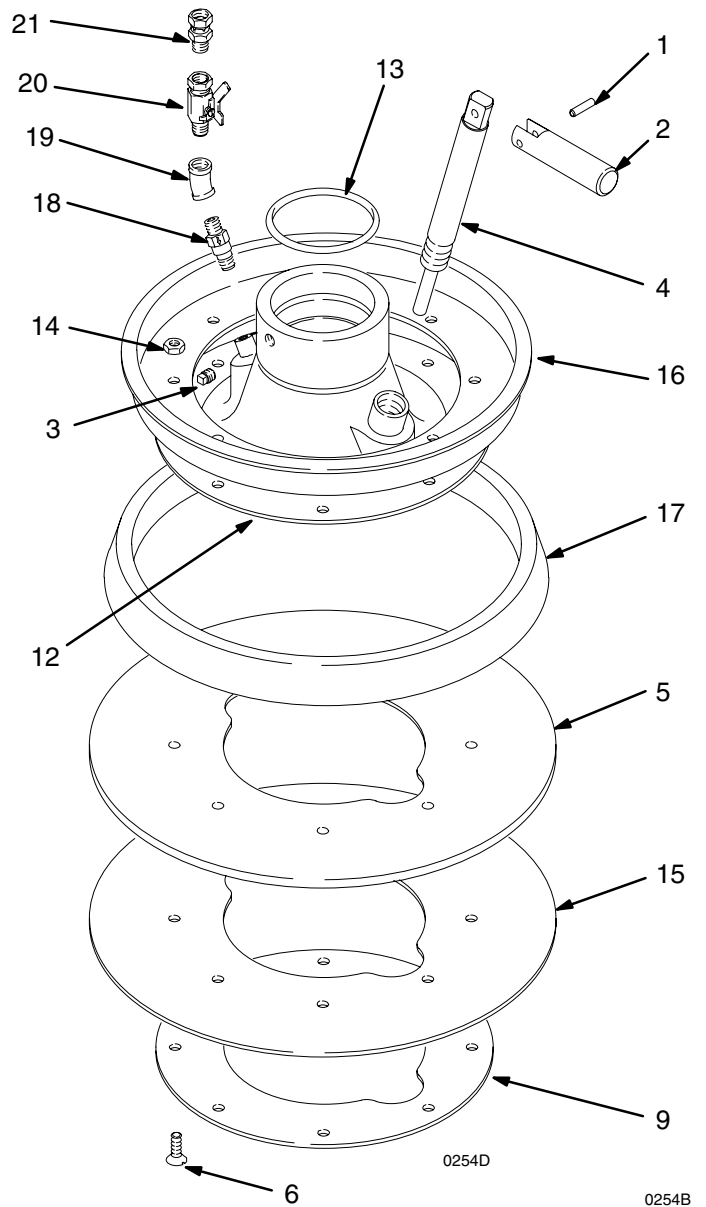

Ref. No.	Part No.	Description	Qty	Ref. No.	Part No.	Description	Qty
1	101831	PIN, spring, straight	1	14	102040	NUT, hex, self-locking; with nylon insert; 1/4-20 unc-3b	8
2	177542	HANDLE	1	15✓	184421	WIPER; polyethylene	1
3	109468	SETSCREW, hex hd, cup point; 5/16-18 x 3/8 in. (9.5 mm) long	2	16	184418	CLAMP, retaining; zinc-plated carbon steel	1
4	166560	STEM, probe	1	17	276049	SPACER; polyurethane	1
5✓	184420	WIPER; synthetic rubber	1	18✓	C20467	FITTING, nipple, reducer	1
6	109469	SCREW, machine, flat-hd; zinc-plated carbon steel; 1/4-20 x 1 in. (25 mm) long	8	19	111842	FITTING, elbow, pipe 45°	1
9	184419	CLAMP, retaining; zinc-plated carbon steel	1	20	208391	VALVE, ball	1
12	222764	PLATE, wiper; zinc-plated carbon steel	1	21	155665	UNION, adapter	1
13	109458	O-RING; fluoroelastomer	1				

✓ Keep these spare parts on hand to reduce down time.

Parts

Model C50010, Series B Carbon Steel Wiper Plate with Buna-N Wiper and UHMWPE Backup

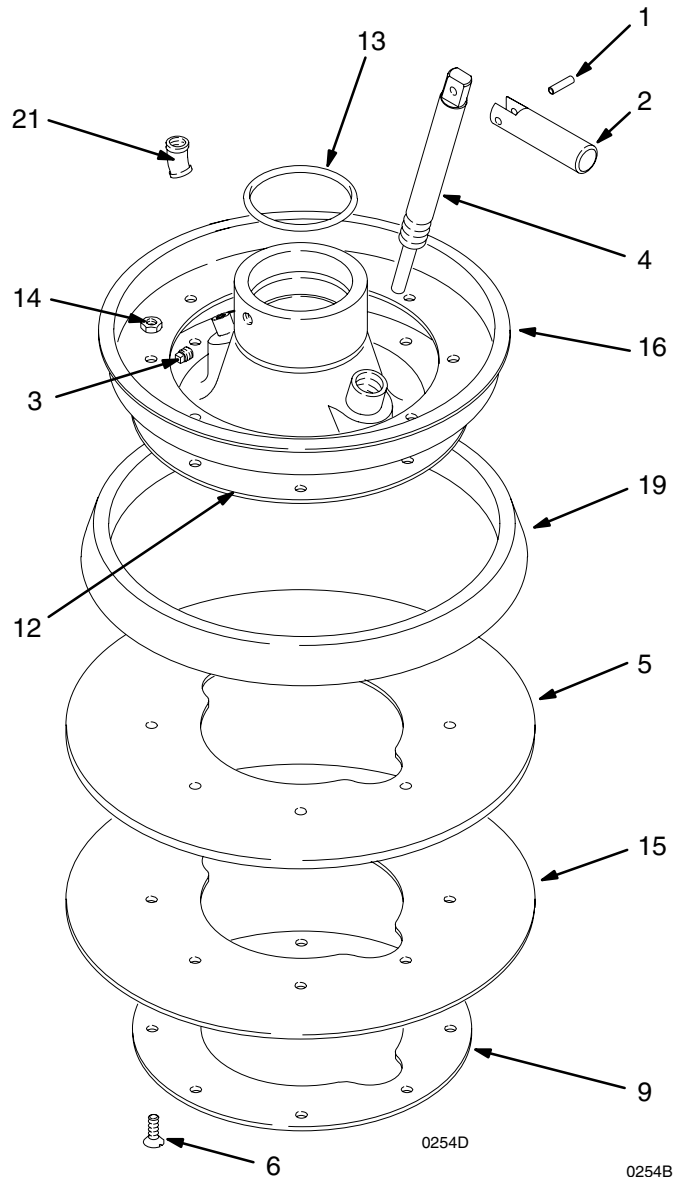

Ref. No.	Part No.	Description	Qty	Ref. No.	Part No.	Description	Qty
1	101831	PIN, spring, straight	1	12	C50009	PLATE, wiper; zinc-plated carbon steel	1
2	177542	HANDLE	1	13	C20153	O-RING; fluoroelastomer	1
3	109468	SETSCREW, hex hd, cup point; 5/16-18 x 3/8 in. (9.5 mm) long	2	14	102040	NUT, hex, self-locking; with nylon insert; 1/4-20 unc-3b	8
4	166560	STEM, probe	1	15	184421	WIPER; polyethylene	1
5	184420	WIPER; synthetic rubber	1	16	184418	CLAMP, retaining; zinc-plated carbon steel	1
6	109469	SCREW, machine, flat-hd; zinc-plated carbon steel; 1/4-20 x 1 in. (25 mm) long	8	19	276049	SPACER; polyurethane	1
9	184419	CLAMP, retaining zinc-plated carbon steel	1	21	114317	VALVE, check, air assist	1

✓ Keep these spare parts on hand to reduce down time.

Accessories

USE GENUINE GRACO PARTS AND ACCESSORIES

Wiper Conversion for Model 222812

If the fluid you are pumping is not compatible with the 184420 synthetic rubber wiper which is standard on Model 222812, order part no. 184551 polyethylene wiper and 184552 PTFE-coated wiper. These parts are standard on Model 235516. Refer to page 13, items 5 and 20, for proper installation.

Shield Kit 223689

Place on the surface of the fluid before the plate enters the pail, to cover the fluid side of the 19 liter (5 gal.) wiper plate and keep it clean. For use with ram-mounted pumps only. Package of 10 disposable polyethylene shields. Shields may be reused, if desired, by removing excess material with a squeegee.

Technical Data

Category	Data
Outer diameter (wiper)	<i>Model 222812, 235516, 222909, 918409, C50010, C50260:</i> 289 mm (11.38 in.); <i>Model 241081: 330 mm (12.99 in.)</i>
Inner diameter (neck)	64.58 mm (2.54 in.)
Wetted parts	<i>Model 222812, 241081, 918409, C50010, C50260:</i> Zinc-Plated Carbon Steel, Synthetic Rubber, Ultra-High Molecular Weight Polyethylene, Cork, Polyurethane, Polyethylene, fluoroelastomer <i>Model 235516:</i> Zinc-Plated Carbon Steel, Nitrile, PTFE, Ultra-High Molecular Weight Polyethylene, Cork, Polyurethane, Polyethylene, fluoroelastomer <i>Model 222909:</i> 304 and 316 Stainless Steel, Nitrile, PTFE, Ultra-High Molecular Weight Polyethylene, Polyurethane, Polyethylene, fluoroelastomer

Graco Standard Warranty

Graco warrants all equipment manufactured by Graco and bearing its name to be free from defects in material and workmanship on the date of sale by an authorized Graco distributor to the original purchaser for use. With the exception of any special, extended, or limited warranty published by Graco, Graco will, for a period of twelve months from the date of sale, repair or replace any part of the equipment determined by Graco to be defective. This warranty applies only when the equipment is installed, operated and maintained in accordance with Graco's written recommendations.

This warranty does not cover, and Graco shall not be liable for general wear and tear, or any malfunction, damage or wear caused by faulty installation, misapplication, abrasion, corrosion, inadequate or improper maintenance, negligence, accident, tampering, or substitution of non-Graco component parts. Nor shall Graco be liable for malfunction, damage or wear caused by the incompatibility of Graco equipment with structures, accessories, equipment or materials not supplied by Graco, or the improper design, manufacture, installation, operation or maintenance of structures, accessories, equipment or materials not supplied by Graco.

This warranty is conditioned upon the prepaid return of the equipment claimed to be defective to an authorized Graco distributor for verification of the claimed defect. If the claimed defect is verified, Graco will repair or replace free of charge any defective parts. The equipment will be returned to the original purchaser transportation prepaid. If inspection of the equipment does not disclose any defect in material or workmanship, repairs will be made at a reasonable charge, which charges may include the costs of parts, labor, and transportation.

THIS WARRANTY IS EXCLUSIVE, AND IS IN LIEU OF ANY OTHER WARRANTIES, EXPRESS OR IMPLIED, INCLUDING BUT NOT LIMITED TO WARRANTY OF MERCHANTABILITY OR WARRANTY OF FITNESS FOR A PARTICULAR PURPOSE.

Graco's sole obligation and buyer's sole remedy for any breach of warranty shall be as set forth above. The buyer agrees that no other remedy (including, but not limited to, incidental or consequential damages for lost profits, lost sales, injury to person or property, or any other incidental or consequential loss) shall be available. Any action for breach of warranty must be brought within two (2) years of the date of sale.

Graco makes no warranty, and disclaims all implied warranties of merchantability and fitness for a particular purpose in connection with accessories, equipment, materials or components sold but not manufactured by Graco. These items sold, but not manufactured by Graco (such as electric motors, switches, hose, etc.), are subject to the warranty, if any, of their manufacturer. Graco will provide purchaser with reasonable assistance in making any claim for breach of these warranties.

In no event will Graco be liable for indirect, incidental, special or consequential damages resulting from Graco supplying equipment hereunder, or the furnishing, performance, or use of any products or other goods sold hereto, whether due to a breach of contract, breach of warranty, the negligence of Graco, or otherwise.

FOR GRACO CANADA CUSTOMERS

The parties acknowledge that they have required that the present document, as well as all documents, notices and legal proceedings entered into, given or instituted pursuant hereto or relating directly or indirectly hereto, be drawn up in English. Les parties reconnaissent avoir convenu que la rédaction du présente document sera en Anglais, ainsi que tous documents, avis et procédures judiciaires exécutés, donnés ou intentés à la suite de ou en rapport, directement ou indirectement, avec les procédures concernées.

Graco Information

TO PLACE AN ORDER, contact your Graco distributor, or call one of the following numbers to identify the distributor closest to you:

1-800-328-0211 Toll Free

612-623-6921

612-378-3505 Fax

All written and visual data contained in this document reflects the latest product information available at the time of publication. Graco reserves the right to make changes at any time without notice.

This manual contains English. MM 308049

Graco Headquarters: Minneapolis

International Offices: Belgium, China, Japan, Korea

GRACO INC. P.O. BOX 1441 MINNEAPOLIS, MN 55440-1441

www.graco.com

5/1990 Revised 5/2007