

GENUINE GRACO PARTS AND ACCESSORIES



Important Safety Instructions

Read all warnings and instructions in manual 308570.
Save those instructions.

241782 & 253545 Check-Mate 800™ Throat Packing Repair Kits

311536A

⚠ WARNING



To reduce the risk of serious injury whenever you are instructed to relieve pressure, always follow the Pressure Relief Procedure. See Instruction Manual 308570.

KIT 241782

Ref No.	Part No.	Description	Qty.
1❖	190585	NUT, packing	1
2❖	113021	PACKING, u-cup	2
4❖	106258	PACKING, o-ring	1
6	195232	WASHER, rod scraper	1
7	195233	WASHER, seal back-up	1
8	195234	WASHER, scraper	1

❖ Apply Lubrication

✓ Torque to 97-106 N.m (71-78 ft-lb)

† Torque to 190-217 N.m (140-160 ft-lb) when installing the wetcup assembly back into the pump.

★ Lips of u-cup packings must face down

See Installation Instructions on Reverse Side.

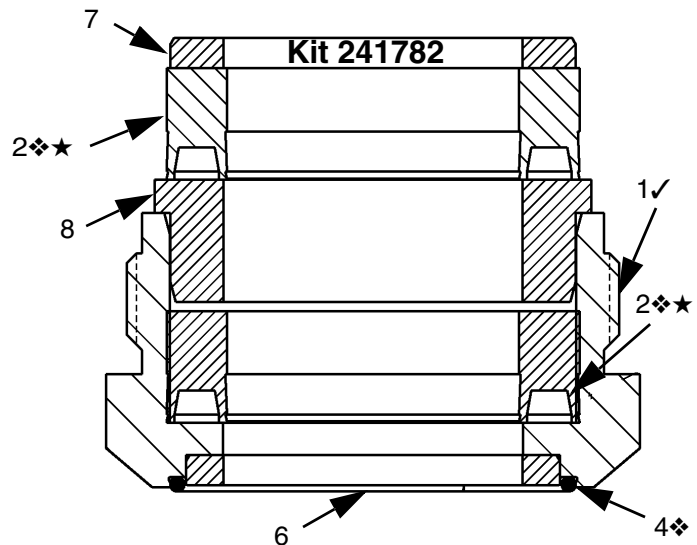

Kit 253545

Ref No.	Part No.	Description	Qty.
1❖	190585	NUT, packing	1
2❖	120286	PACKING, u-cup	2
4❖	106258	PACKING, o-ring	1
6	195232	WASHER, rod scraper	1
7	195233	WASHER, seal back-up	1
8	120284	WASHER, scraper	1
10	115982	LUBRICANT, synthetic	1

❖ Apply Lubrication

✓ Torque to 305 +/- 14 N.m (225 +/- 10 ft-lb)

† Torque to 190-217 N.m (140-160 ft-lb) when installing the wetcup assembly back into the pump.

★ Lips of u-cup packings must face down

See Installation Instructions on Reverse Side.

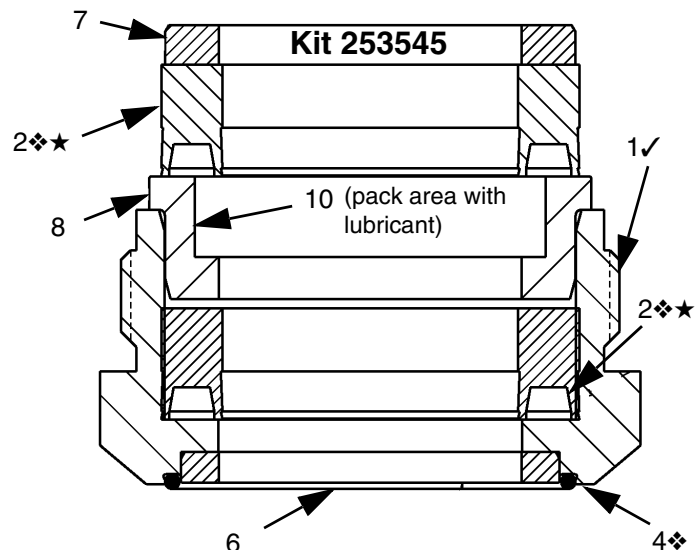



Graco Inc. P.O. Box 1441 Minneapolis, MN 55440-1441

311536 Rev. A 5/2006

Copyright 2006, Graco Inc. is registered to I.S. EN ISO 9001

Installation

It will take approximately 30 - 45 minutes to change throat packings on a warm Therm-O-Flow unit. The only tools needed are a large slip-joint pliers, a small slip-joint pliers and an adjustable wrench. **WEAR LEATHER GLOVES, PROTECTIVE SLEEVES AND EYE PROTECTION WHEN WORKING ON WARM UNIT!**

1. While the pump and follower plate are hot, raise the follower plate from the surface of the material, **but not out of the drum**. Open the pump bleed port or trigger the gun and pump as much adhesive out of the pump as possible. **Keep the bleed port open to be sure all pressure is relieved.**
2. If a lot of material has collected in the wet cup, clean it out so it does not restrict the shaft.
3. Disconnect the air motor from the pump connector rod using small slip-joint pliers and the adjustable wrench. Remove the coupler nut.
4. Retain the half-moon shaped shims from the coupler nut. These must be reinstalled when you reassemble the pump.
5. Jog the air motor to force the pump plunger into the down position, then slowly raise the air motor plunger rod. Keep hands clear of the moving parts. The plunger should disconnect from the air motor. Allow the air motor to reach the top of its stroke and shut off the air. **Lock off the air motor control ball valve.**
6. Remove the coupling nut/wet cup assembly with the large channel lock. Be sure that the o-ring seal on the bottom of the assembly comes out.
 It may be necessary to loosen the top screws on the pump heat shroud to remove and install this assembly.
7. Remove the old packing assembly, clean off the shaft, wet cup and threaded area. Lubricate the shaft with lithium grease.
8. Install new packing kit 241782 or 253545. If you have a series A pump that was built before May 1999, you will also need to replace the packing nut with part no. 237799.
9. Reassemble the wet cup. Reconnect the pump to the air motor plunger. **Keep hands clear of moving parts.** In order for the nut to catch the threads it may be necessary to raise the pump-lower shaft. Don't forget to reinstall the shims. Refill the wet cup with throat seal liquid. Lower the platen to the surface of the material, prime the pump to complete the procedure.
 The tolerances on the Check-Mate pump are very tight to prevent leaking. If the assembly cools down too much, it will be too tight to reinstall on the shaft. Should this happen, re-warm the assembly in an oven, or by placing it on the warm platen for a while before attempting to reassemble the pump.

All written and visual data contained in this document reflects the latest product information available at the time of publication. Graco reserves the right to make changes at any time without notice.

MM 311536

Graco Headquarters: Minneapolis
International Offices: Belgium, China, Japan, Korea

GRACO INC. P.O. BOX 1441 MINNEAPOLIS, MN 55440-1441

www.graco.com

Printed in USA 311536A

5/2006